

FW Murphy Engine Integrated Control System – EICS – has improved the performance of smaller horsepower packages worldwide. We are adapting this groundbreaking technology to the large horsepower segment.

EICS®-VHP
ENGINE INTEGRATED CONTROL SYSTEM

- New Mass Flow Air Valve & Mass Flow Gas Valve Designed for Application
- Designed & Tested Specifically for Large Engines
- Increases Uptime and Reduces Costs

We Make
BIGGER
Engines
BETTER

FW Murphy revolutionized engine management a decade ago with the introduction of EICS. For the next step, we've moved to larger horsepower engines to maximize our Engine Integrated Control System for the VHP engine.

EICS combines key components – ignition system, air/fuel control, speed governing, interface diagnostics, sensors, harnesses and catalyst – in one package saving money and man-hours in installation and setup of separate engine components.

Engineered for VHP Series Waukesha engines, EICS VHP maintains emission compliance, optimizes performance and simplifies engine diagnostics. Currently available is the 7042GSI with the 7044GSI to follow soon. Future variants planned are the 5790 and 5794.

The creation of the newly engineered Mass Flow Air Valve (MFA) and the Mass Flow Gas Valve (MFG) by FW Murphy maximizes performance and emission reductions. Our multi-year, multi-million dollar investment in creating this technology will keep your large engine running at its peak.

This EICS variant designed and tested for these specific engines eliminates the need for manual adjustments and reduces costs.



Get the most out of your big engine.
Contact 360 Compression Services today.

EICS-VHP

ENGINE INTEGRATED CONTROL SYSTEM



HMI PANEL >



MFG >

MFA >



ENGINE HARNESS >

Large Engine Integrated Control System Elements

Designed and dyno- and field-tested for VHP engines, this EICS variant has specific parts that maximize these mapped VHP engines. FW Murphy's high horsepower system optimizes performance, simplifies diagnostics and maintains engine compliance.

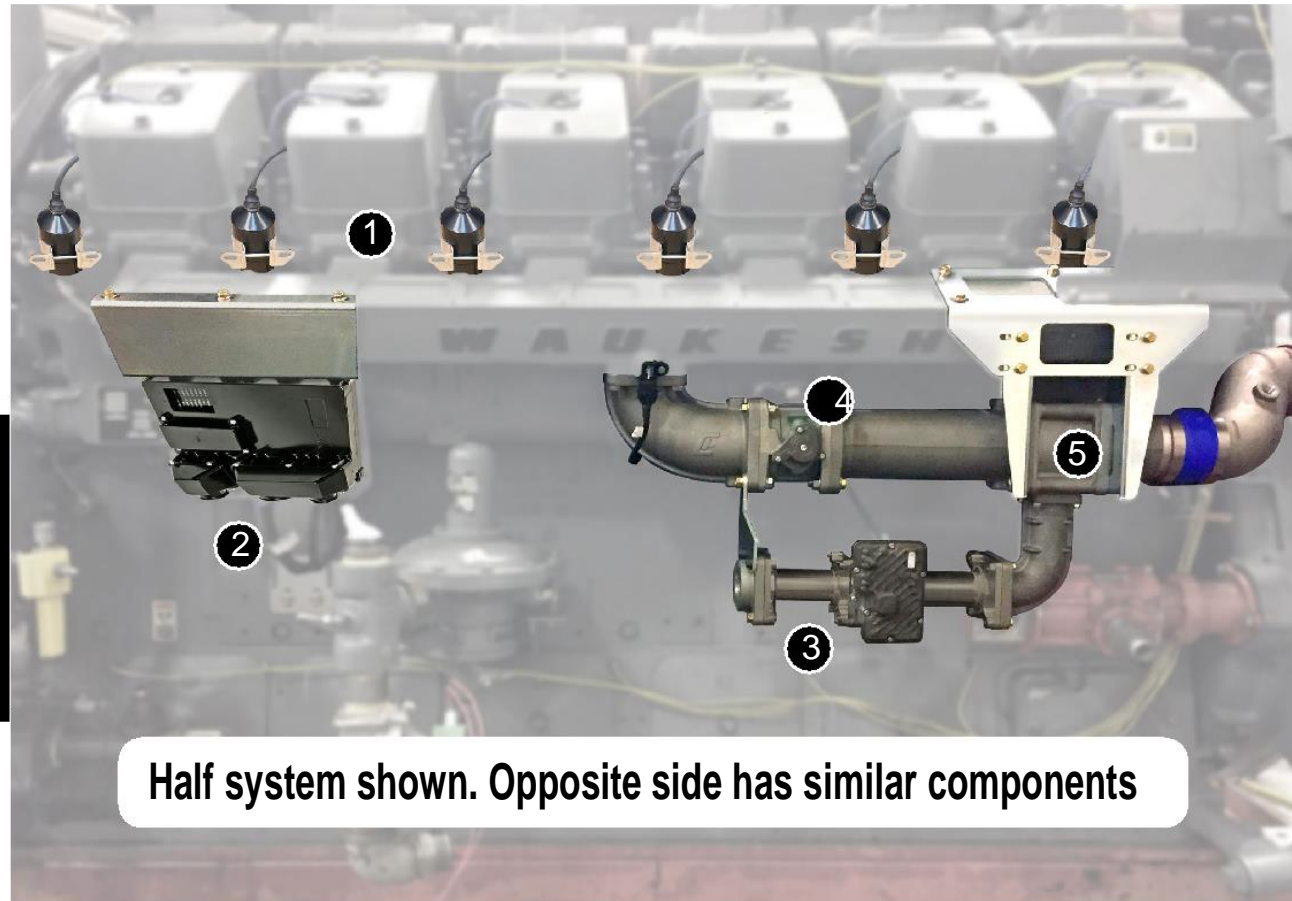

Half system shown. Opposite side has similar components

- ① SMART COIL™
- ② ECM
- ③ MFG
- ④ MFA
- ⑤ FIXED VENTURI MIXER

All trademarks used in this document are the property of their respective owners.